

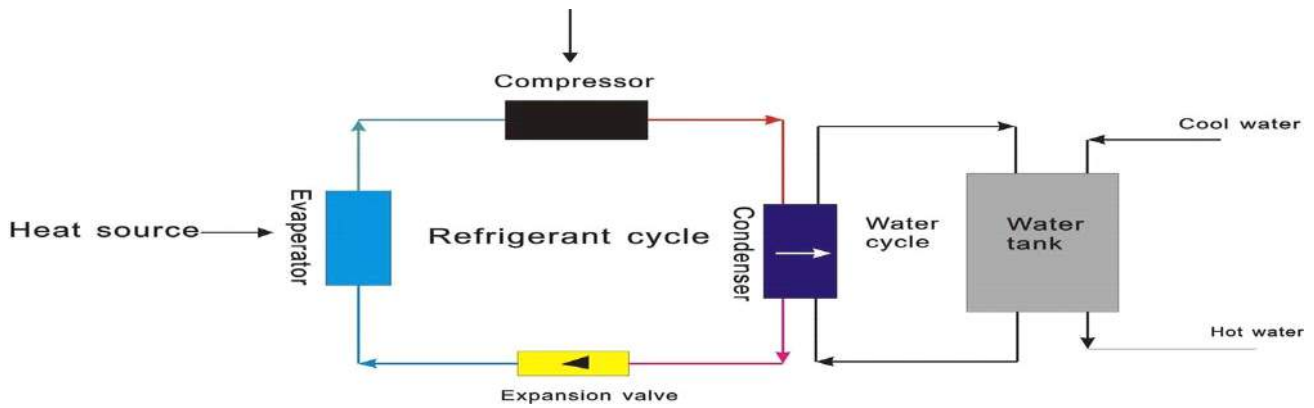

# Air to water heat pump

Operational Instructions



## ※ I 、 Summarize

The controller fir for single or double compressor(single phase& three phase) air source , direct outlet hot water or circulating heating type heat pump water heater. The control system consists of main board, control panel, thermostat(optional).

## ※ II 、 Main technical parameters

### 1. Use condition:

- ★Operating voltage: AC220~240V/380~410V±10%, 50Hz~60Hz±1Hz
- ★Operating environmental temperature: -20~+75℃
- ★Store temperature: -30~+80℃
- ★Relative humidity: 0~95%RH

### 2. Temperature control precision: 1℃

### 3. The control board complies with the follow requirement:

- GB4706.1-1998 “Household and similar electric equipment’s safety part 1—currency Requirement
- GB4706.32-1996 “Household and similar electric equipment’s safety , heat pump, air Conditioner and dehumidifier’s special requirement
- GB18430.1-2001 “Steam compressor cycle cooling water heat pump machine suit for industry and commerce using and relevant using
- GB18430.2-2001 “Steam compress cycle cooling water heat pump machine, household and similar purpose cooling water (heat pump) units.”
- Anti-jamming degree complies with GB4343. 2-1999
- Printed Circuit Board comply with GB4588.1 and GB4588.2’s rule

## ※III、 The main function of control panel

1. Heating and/or cooling water function
2. Show Water tank temperature, preset temperatures, running state, output state, clock and so on.
3. Can inquire about evaporator pipe temp, environmental temperature, exhaust temp, and return gas temp, outlet water temp, return water temp, current of compressor, electric expansion valve opening, error code and so on.
4. Automatically remember all parameters, if power off, and resume running automatically after power on.
5. Clock work on after power off, needn’t readjust every time.
6. Turn on/off at two certain period of time within 24 hours.

7. Supply hot water at two certain period of time within 24 hours.
8. Amend running parameters to be best at all kinds of working condition.
9. Electric expansion valve is control automatically (according to the degree of superheat to adjust in time)
10. Automatically defrosting function (it has dropping water function when defrosting)
11. Forced defrosting function.
12. Key-press locked automatically.
13. Function of time limited via password
14. Huge LCD with blue background and white words showing.
15. Perfect protect function (lack of phase and wrong phase protection of 3-phase supply, compressor over current protection, high pressure protection, low pressure protection, lack of water protection and so on).
16. High, middle, low water level sensor test showing on control panel
17. Function of supply water automatically (can supply water according to temp, also can supply water not according to temperature)
18. Return water function
19. Anti-frost function
20. Heat pump can indentify automatically and start up to heat water under the condition of without control panel (or control panel is broken)

## ※IV、Main board

### ◇ 1.Control board input

Low water level switch (lead or probe)	Middle water level switch (lead or probe)
High water level switch (lead or probe)	Low pressure switch
High pressure switch	Water flow switch
Water pressure switch	Three phase A-B-C-N

### ◇ 2.Control board output

Circulating pump(contact current 20A)	Auxiliary electric heating(contact current 8A)
Fan motor (contact current 8A)	Water Supply valve (contact current 8A)
Compressor (contact current 20A)	Four way valve (contact current 8A)
Crankcase Heating (contact current 8A)	Return water pump (contact current 8A)
Hot water supply pump (contact current 8A)	

### ◇ 3.Control board simulation signal input

Water tank temperature (range of measure:0-160 dc ),
Evaporator pipe coil temperature (range of measure:-30-110 dc)
Return gas temperature (range of measure:-30-110 dc)
Exhaust temperature (range of measure:0-160 dc)
Environmental temperature (range of measure:-30-110 dc)
Outlet water temperature (range of measure: 0-160 dc)
Return water temperature (range of measure: 0-160 dc)
Compressor current (range of measure: 0-30 A)

※ V、 **Control panel illustration**

■ **1、 Control panel picture:**

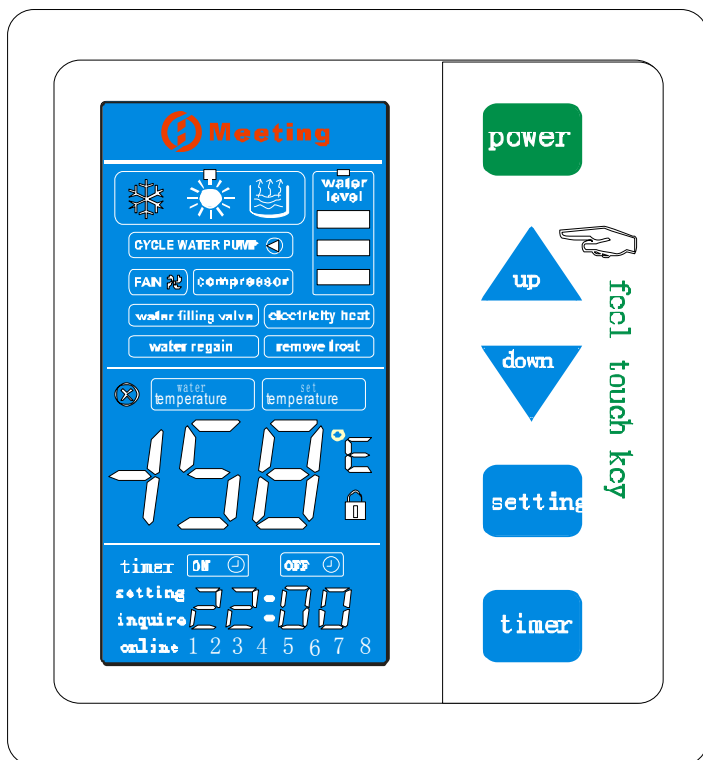

■ **2. Operate:**

Control panel power-on, buzzer give a long ringing ,LCD display, background light give micro light, now, the key-press are locked, it is ineffective to touch any key.

**2. 1 Unlock key-press:**

Touch “power” key by finger for more than 3 seconds, after hear “toot” sound ,move away finger, now background light give high light, key-press are unlocked, key-locked signal disappear (60s later, if any key isn’t pressed, key can be locked automatically, key-locked signal display).

**2. 2 On/off :**

Touch “power” key by finger, if control panel is under ON state, then Power off, if control panel under OFF state, then power on.

**2. 3 Water tank temperature setting :**

Touch“▲”, “set temperature” signal flash and display the preset temperature of water tank, touch “▲”again, the preset temperature of water tank increase. Touch“▼”, “set temperature ”signal flash and display the preset temperature of water tank, touch “▼”again, the preset temperature of water tank decrease. The setting range of water tank is 20 ℃ to 60℃.

**2. 4 Definite time setting:**

Touch “timer ”key, enter definite time setting state.

First adjust the “hour” of the first period of definite time for power-on, then touch” timer” key again, then adjust the “minute” of the first period of definite time for power-on, touch timer“ key again, then adjust the “hour” of the first period of definite time for power-off, touch “timer” key again, then adjust the “minute” of the first period of definite time for power-off. Touch “timer ”key again, enter the second definite time setting, the operation is the same as the first definite time setting ,until finish all the definite time setting, then quit setting.

After quit definite time setting, it display the  ON  and  OFF  signal.

**2. 4. 1 Cancel definite time:**

Press “timer” key for 3s, hear a “toot” voice, then move away finger, then definite time setting canceled

**2. 5 Clock setting:**

Press “timer” key for 3s, hear a “toot” voice, press continually, after press the “timer” key for 8s, when hear “toot” voice again, then move away finger, enter clock setting state,

First adjust the “hour” of clock, press “timer” key again, then

“Minute” of clock, press “timer” key again, then finish setting and quit setting.

Note: clock setting just can be operated under the condition of there isn’t definite time set.

**2. 6 Force defrosting:**

After the heat pump was power on and the compressor has started, then press “▼” over 8s, when hear a “toot” voice, move away finger, then enter defrost state, when the temperature of coil (evaporator) or defrosting time reach preset parameter, then quit defrost.

**2. 7 Cooling mode:**

Under heating water mode, press “▲” key over 8s, then hear a “toot” voice, enter cooling mode.

Range of water temperature adjusting: 7°C-30°C, under cooling mode, then press “▲” over 8s, enter heating mode.

**parameter setting and inquiry ( attached table 1 )**

**A. Function inquiry:**

Under power on state, press “setting” key, inquiry code is from A1 to A9, if single compressor heat pump,

Press “setting” key again, then quit inquiry state, if double compressor heat pump, another 9 inquiry code can be inquired, from b1 to b9, press “setting” key again, quit inquiry state. Please check following stable:

Inquiry code	Meaning( single compressor Heat pump)	Meaning( double syst)	Code	Meaning( double syst)
A1	Coil(evaporator) temperature	Coil(evaporator) temperature 1	b1	Coil(evaporator) temperature 2
A2	Return gas temperature	Return gas temperature 1	b2	Return gas temperature 2
A3	Exhaust temperature	Exhaust temperature 1	b3	Exhaust temperature 2
A4	Environment temperature	Environment temperature	b4	Environment temperature
A5	Outlet water temperature	Outlet water temperature	b5	Outlet water temperature
A6	Return water temperature	Return water temperature	b6	Return water temperature
A7	00	00	b7	00
A8	Compressor current	Compressor current 1	b8	Compressor current 2
A9	Opening angle of expansion valve	Opening angle of expansion valve 1	b9	Opening angle of expansion valve 1
Er	Display of error code	Display of error code	Er	Display of error code

**B. Function setting:**

Under power on state, press “setting” key over 3s, when hear “toot” voice ,move away finger, enter parameter setting state, after parameter set, press “setting” key ,enter next parameter setting, until all the setting of parameters are finished ,then quit setting.



Set code	Parameter name	range	Initial
///	Water tank temperature	20°C—60°C	50°C
L1	Temp difference between water tank real temp and display temp	0°C—15°C	0°C
L2	Temp difference between compressor start restart and preset water tank temp	3°C—18°C	5°C
L3	Set supply hot water temp	35°C—99°C	55°C
L4	Water tank temp upper limit setting	30°C—99°C	60°C (swimming pool Heat pump is 45°C)
L5	environment temp at which electric heating startup	0°C—35°C	0 (0 mean nonelectric heat)
L6	Return water temperature	30°C—65°C	45°C
L7	Temp at which cool water supply allowed	20°C—60°C	20°C (20°C means cool water can't be supplied)
L8	Compressor current	0-48A	0(0 means not detect )
h1	Cycle of defrost	20—99min	35min
h2	Temp of enter defrosting	-15°C—1°C	-1°C
h3	Runtime of defrost	5-20min	10min
h4	Temp of quit defrosting	1°C—40°C	20°C
p1	Cycle of electric expansion valve regulating	20-180S	30s
p2	Degree of superheat	-8°C—15°C	0
p3	Exhaust temp allowed when expansion valve adjusting	70°C—135°C	90°C
p4	Electric expansion valve opening angle when defrosting	6-55degree	50 degree
p5	Min opening angle of electric expansion valve	6-30degree	15 degree
P6	Compensation of superheat degree	0-12°C	4°C

### C. Error code display and alarm:

Code	Description of fault of single compressor system	Code	Description of fault of double compressor system
01E	wrong phase	01E	wrong phase
02E	Lack of phase	02E	Lack of phase
03E	Water flow switch	03E	Water flow switch
05E	High pressure	05E	High pressure 1
06E	Low pressure	06E	Low pressure 1
07E		07E	High pressure 2
08E		08E	Low pressure 2
09E	Communication	09E	Communication
11E	Limit time	11E	Limit time
12E	Exhaust temperature too high	12E	Exhaust temperature 1 too high
13E		13E	Exhaust temperature 2 too high
15E	Water tank temp sensor damaged	15E	Water tank sensor damaged
16E	coil pipe(evaporator)sensor damaged	16E	coil pipe(evaporator)sensor1damaged
17E		17E	coil pipe(evaporator)sensor 2damaged
18E	Exhaust sensor damaged	18E	Exhaust sensor1 damaged
19E		19E	Exhaust sensor 2 damaged
21E	Environment sensor damaged	21E	Environment sensor damaged
22E	Return water sensor damaged	22E	Return water sensor damaged
23E		23E	
25E	Water level switch damaged	25E	Water level switch damaged
26E		26E	
27E	Outlet water sensor damaged	27E	Outlet water sensor1 damaged
28E		28E	Outlet water sensor2 damaged
29E	Return gas sensor damaged	29E	Return gas sensor1 damaged
30E		30E	Return gas sensor 2 damaged
31E	Water pressure switch damaged	31E	Water pressure switch damaged
32E	Cooling water temp too low	32E	Cooling water temp too low
33E		33E	
34E		34E	
35E	Compressor over current	35E	compressor 1 over current
36E		36E	compressor 2 over current

※VI、Function description

● 1、Heating

1.1 Hydronic heating

1.1.1 Flowsheet of hydronic heating

power on→water level switch test→ water pressure switch test→cycle water pump work(16s)→ water flow switch test→fan work (6s) →compressor work (when low water level disconnect, cool water supply switch on, compressor、 fan、 cycle water pump work.

1.1.2、 Cool water supply controlling

- ( 1)、 when low water level switch disconnected, cool water supply switch on and begin supply water, cycle water pump startup, fan off, compressor off.
- ( 2)、 when low water level switch on, cycle water pump on, fan on,compressor on, hydronic heating begin. meanwhile water supply valve begin to supply water according to the preset water supply temp L7.: if water tank temperature $\geq$ L7, water supply valve open, supply water; if water tank temperature $\leq$  L7-5degree, water supply valve close, stop supplying water.
- ( 3)、 after high water level close up, stop supplying water. If high water level has closed up before, when it disconnect again, not supply water at once, it will supply water until middle water level disconnect.

Notice:: if L7=20°C,water supply is not controlled by water temperature.

1.1.3、 Water temperature controlling

Range of water temperature controlling: 35-60°C ,

1.1.4 Running controlling

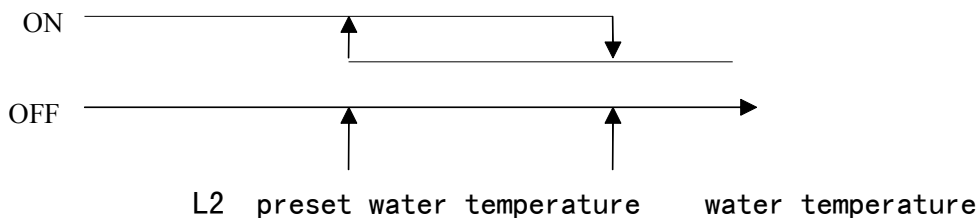

1.2 Instantly heating

1.2.1

Power on→water pressure switch test→open water supply valve to supply water→fan on→compressor on, after high water level connected, water supply valve close, if water tank temperature doesn't reach preset temperature, cycle water pump on, water was heating to preset temperature circularly, then power off.

1.3 Supply water controlling

- ( 1) when high 、 middle、 low water level switches all disconnect, water supply valve supply water, then check water pressure switch, if water pressure switch is closed up, then fan on, compressor on, thermostat on, begin to supply water unstill high water level switch closed up, thermostat and water supply valve close ,stop supplying water.
- ( 2) if high water level switch have been closed up, when the high water level switch disconnect, it will not supply water at once, it must unstill middle water level disconnect. Then water supply valve on, fan on, compressor on, thermostat on.

1.4 Water temperature controlling

Range of water temperature controlling: 35-65°C , when preset temperature reach 60°C, if want to set the water temperature  $>$  60°C, press ▲ key over 6s , when hearing a “toot” voice , move away finger , press ▲ key again, now the max water temperature can be set at 65°C.



**1.4.1 Running controlling**

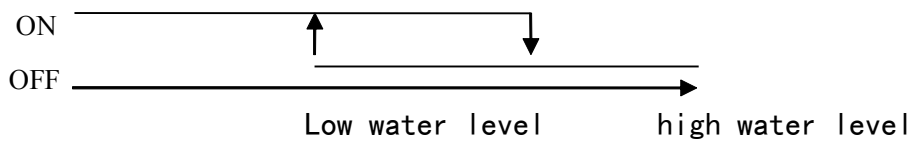

**● 2 、 Auxiliary electric heating controlling**

**2.1 Condition of auxiliary electricity heating startup**

- A. under heating hot water state;
- B. water tank temperature  $+5^{\circ}\text{C} \leq$  preset temperature
- C. water tank temperature  $< 45^{\circ}\text{C}$ ;
- D. environmental temperature  $\leq L5$

All of the above conditions are met at the same time, the auxiliary electric heating startup.

**2.2 Condition of auxiliary electricity heating stop.**

- A. under forced defrosting state;
- B. water tank temperature  $\geq$  preset temperature
- C. water tank temperature  $\geq 50^{\circ}\text{C}$
- D. environmental temperature  $> L5$

Any one of above conditions is met, the auxiliary electric heating will stop

**● 3、 Defrosting running**

( at the condition of parameters are not changed, the default defrosting process of system is following, if need amending, then defrosting will be according to the amended method )

**3.1、 conditions of enter defrosting**

A, cumulative runtime of compressor reach 35 minutes when heating, and continuing runtime over 6 minutes

B, evaporator copper pipe temperature under  $h2$  (the original values  $-1^{\circ}\text{C}$ , changeable);

If both A,B conditions are met, then enter defrosting, from beginning to the end of defrosting, LCD display defrosting signal. (when defrosting, cycle water pump on, 4-way valve on, compressor on, fan off, thermostat off)。

C, Running state when defrost:

Compressor off, fan off, postpone 50s , 4-way valve open, postpone 40s still , compressor on, cycle water pump on.

**3.2、 conditions of quit defrosting**



A: Evaporator coil pipe temperature  $\geq h4$  (original value is  $12^{\circ}\text{C}$ , changeable)

B: Defrosting time  $\geq h3$  ( original value is 10 minutes, changeable) Note: any one of above condition is met, System quit from defrosting, specific action and time sequence as following chart:

C: Running state: compressor off, fan on, postpone 60S, four way valve off, postpone 30s still, compressor on, cycle water pump on.

### 3.3 Forced defrosting

Under the condition of power on, and compressor startup to heating water, Touch ▼ key over 8s, when hear a “toot” voice, move away finger, enter forced defrosting state at once, when forced defrosting meet preset time or preset temperature, system quit from forced defrosting state automatically, enter normal heating hot water state.

#### ● 4、Cooling water running :

After heat pump power on, touch ▲ key for over 8s, when hear a “toot ” voice, move away finger, enter cooling water mode, touched ▲ key again for over 8s, when hear “toot ” voice, move away finger, then enter heat hot water mode.

#### ● 5、Cycle water pump:

Water pump turn on when heat pump running, if heat pump stop, postpone 30s, then water pump stop (if select instantly heating mode, when water supply valve and thermostat turn on, then cycle water pump turned off, it just turn on when the water in tank need to reheat) .

#### ● 6、four way valve:

4-way valve turn off at normal heating water state, it just turn on when defrost. But if cooling water, it turn on.

#### ● 7、 Water supply valve:

Refer water supply controlling (when defrosting, it doesn't supply water )

#### ● 8、crankcase heating :

When environment temperature  $< 8^{\circ}\text{C}$ , crankcase turns on, when compressor startup, crankcase heating stop. if compressor don't run within one hour, crankcase heating turns on; When environment temperature  $\geq 8^{\circ}\text{C}$  , crankcase heating stop.

#### ● 9、 Return water valve :

The condition of return water valve open

- A. Low water level switch on
- B. Water tank temperature  $\geq L6+5^{\circ}\text{C}$
- B. Return water temperature  $\leq L6$
- D. The preset interval time of water return is reach.

Above conditions are met at the same time, return water valve open.

The condition of return water valve close:

When Return water temperature  $\geq L6$ , return water valve close.

#### ● 10、Automatically running:

Under the condition of no control panel or control panel is damaged, system check about 1 minute, confirm there is not control panel enter automatically controlling.

When run automatically:

Water tank preset temperature =  $55^{\circ}\text{C}$

Preset outlet water temp of direct outlet water =  $50^{\circ}\text{C}$

Deviation value of Water tank temperature = 0

Temp difference at which Compressor can restart after compressor stop =  $5^{\circ}\text{C}$

Period of defrosting = 35 minutes

Temperature at which system enter defrost state =  $-5^{\circ}\text{C}$

Defrost runtime = 8 minutes

Temperature at which system quit defrost state =20°C

Temperature at which electric heating startup=10°C

Return water temperature=45°C

Water supply temperature=40°C

Degree of superheat=0°C

No check compressor current.

## ※ VII、 Protection illustration

- 1、 Protection of compressor postpones 3 minutes, both compressor turn on and off need 3 minutes. every time, compressor needs 3 minutes to restart after it stopped.
- 2、 Water flow switch protection (hydronic heating system use it ). After press “power” key, and cycle water pump run, if water flow switch off, then compressor and fan off.
- 3、 High exhaust temperature protection: when exhaust temperature $\geq 115^{\circ}\text{C}$   
And last 30s, system consider temperature is too high, close output, display error code, 3 minutes later system can restart.
- 4、 High pressure protection : when high pressure switch disconnect 3 times within an hour, display panel show error code and alarm. Then compressor off, fan off, cycle water pump off. After high pressure switch recover , postpone 3 minutes ,compressor restart, If high pressure switch disconnect over 3 times within an hour, control panel lock the error, turn off all output signal, and will not restart whether pressure switch will recover or not.
- 5、 Low pressure protection. when low pressure switch disconnect 3 times within an hour, display panel show error code and alarm. Then compressor off, fan off, cycle water pump off. After low pressure switch recover, postpone 3 minutes, compressor restart. If low pressure switch disconnect over 3 times within an hour, control panel will lock the error, close all output signal, and will not restart whether pressure switch will recover or not..(Remarks: when defrosting, or within 5 minutes after compressor startup, system doesn't test low pressure switch)
- 6、 Sensor error: if sensor occurs error(broken circuit or short circuit), all output stop, and show error code. Sensor can restart after error disappears.
- 7、 Three phase protection: when dial switch 1 select number side, it has three phase test function, it will test three phase supply as soon as power on. If lack of phase or wrong phase , system will enter three phase protection, turn off all output and show error code, it will recover only when trouble removal and power on again.
- 8、 Anti-frost protection: when environment temperature $\leq 5^{\circ}\text{C}$ , if compressor under stopping state over 30 minutes, then cycle water pump will start and run 30S.( cycle water pump work 30s per 30 minutes)
- 9、 Water pressure switch protection: cool water supply magnet valve open, after controller detected water pressure switch off for 6s continually, turn off all output, show error code, until water pressure switch on. System will restart 3 minutes later
- 10、 Compressor over current protection: after compressor started and runs for 6s, test compressor current, if compressor current $\geq L8$  and last 6s, turn off all output, if the over current is caused by lack of phase ,then the control panel will show lack of phase error code and alarm, system will restart after fault removal.

## ※ VIII、 Single compressor heat pump main board illustration

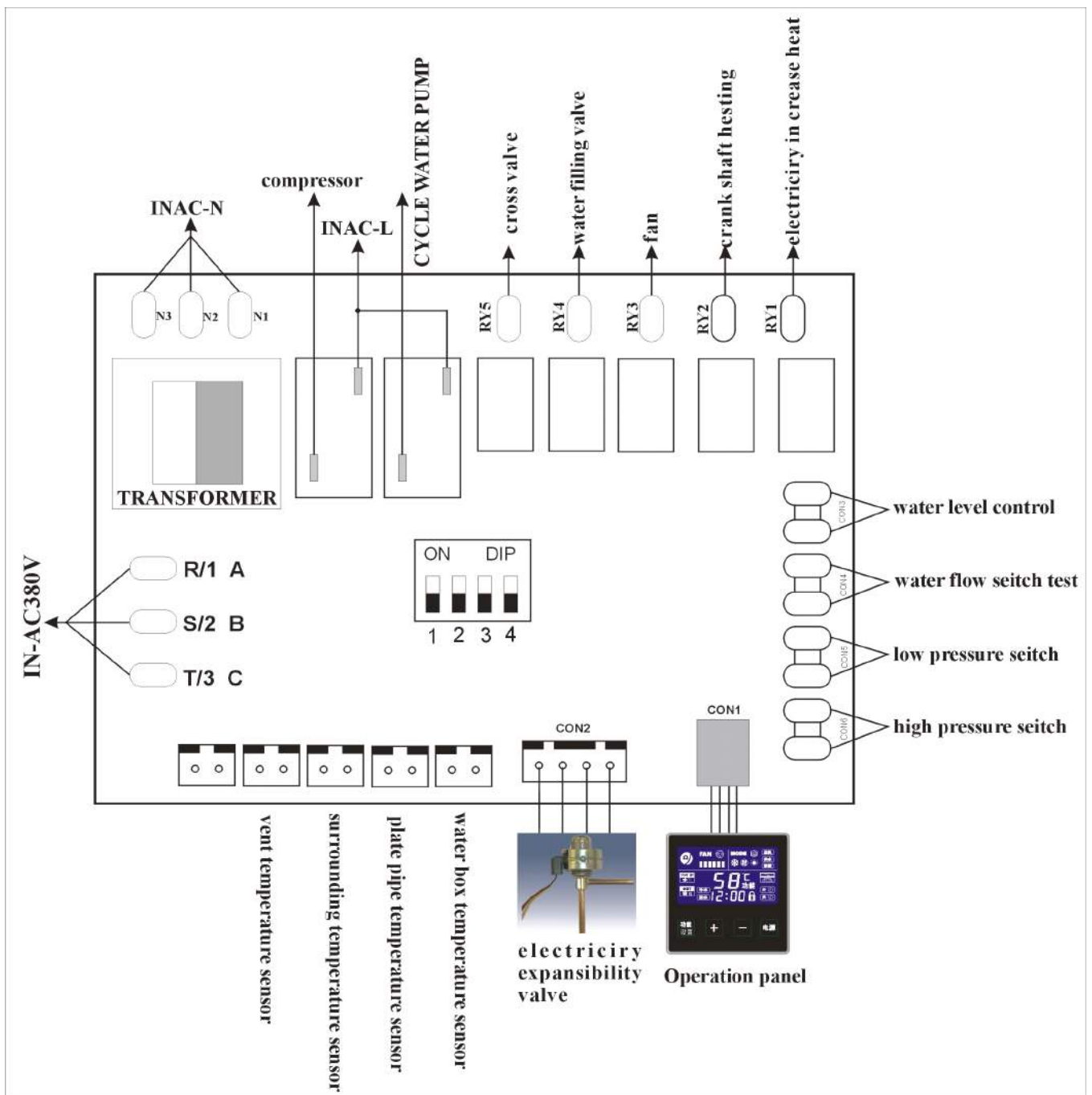

**Remarks:**

Dial switch 1 select ON side is single-phase supply, select number side is three-phase supply.

Dial switch 2 select ON side is common heat pump, select number side is swimming pool heat pump.

Dial switch 3 select ON side is non-online, select number side is online..

When select linkage, if linkage switch on , then postpone 16s , cycle water pump start, then 16s later , fan start, then 16s later, compressor start.

Dial switch 4 select ON side is circular mode, select number side is straight outlet + circular mode.

※IX、 Double compressor heat pump main board

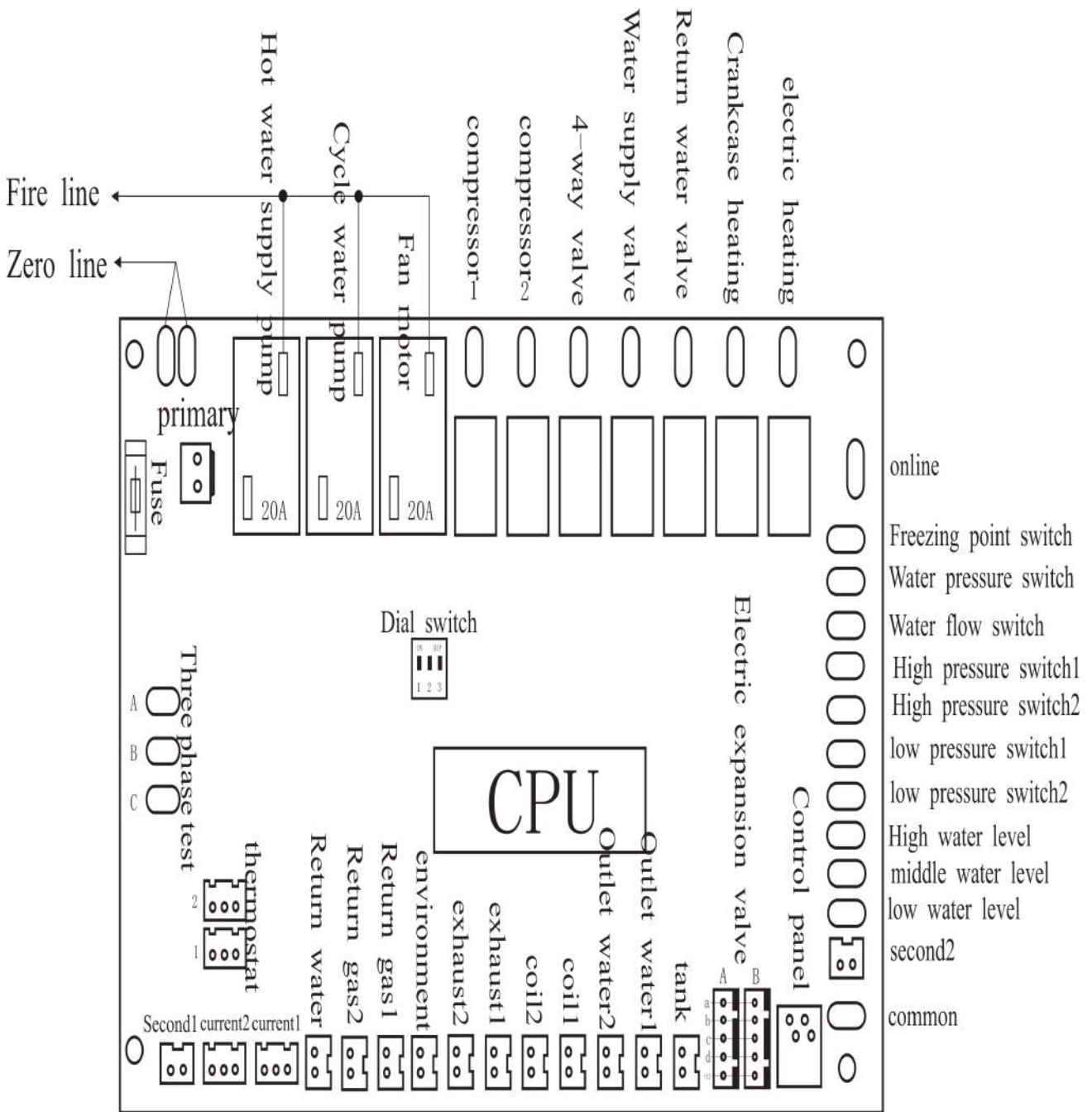

Remarks: 1:

Dial switch 1 select on side is 1phase supply, select unnumber side is 3phase supply.

Dial switch 2 select on side is common air source heat pump, select number side is swimming pool heat pump.

Dial switch 3 select on side is hydronic heating mode, select number side is direct outlet+hydronic heating mode.

◆ 380V single compressor heat pump wiring diagram

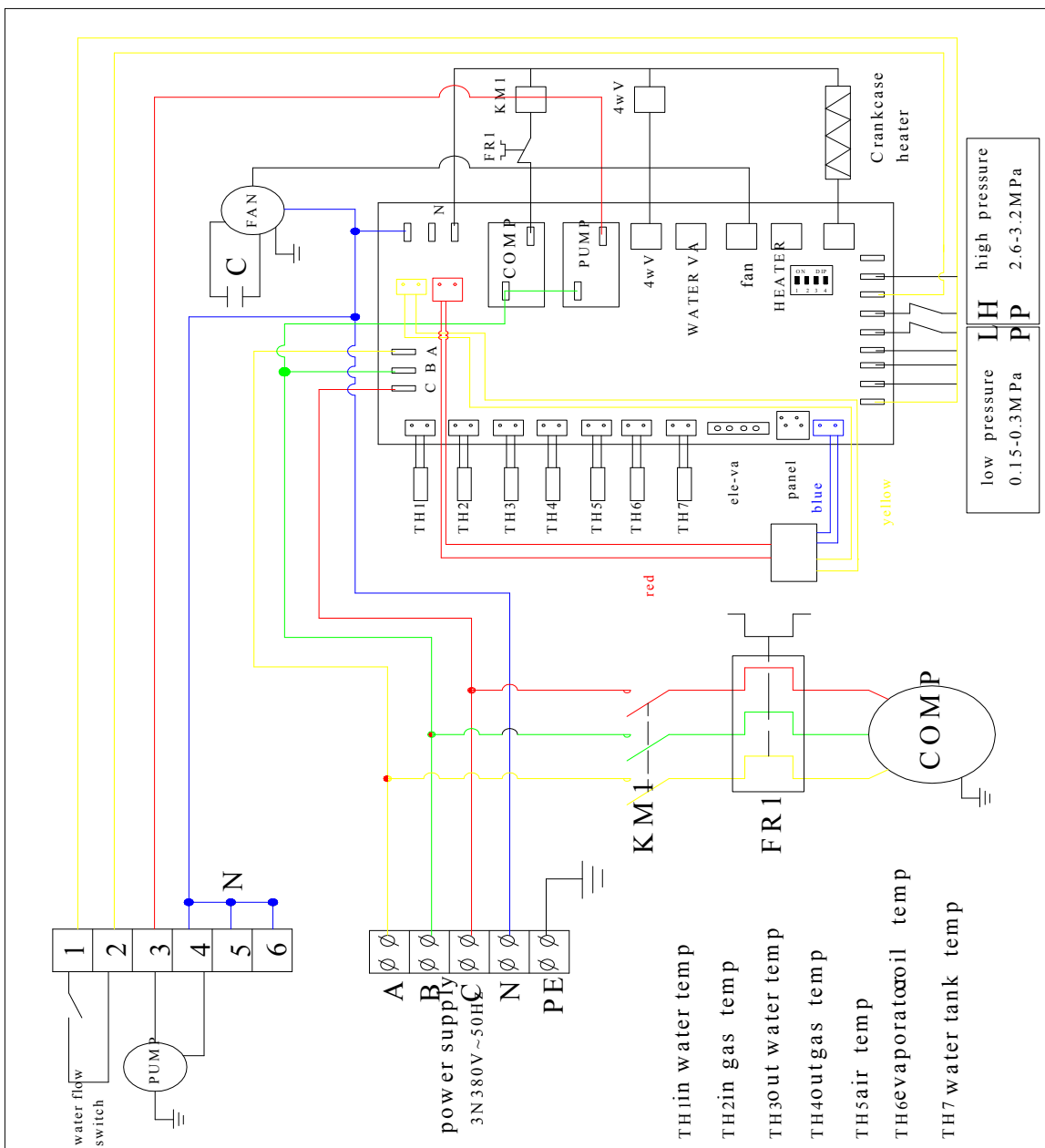
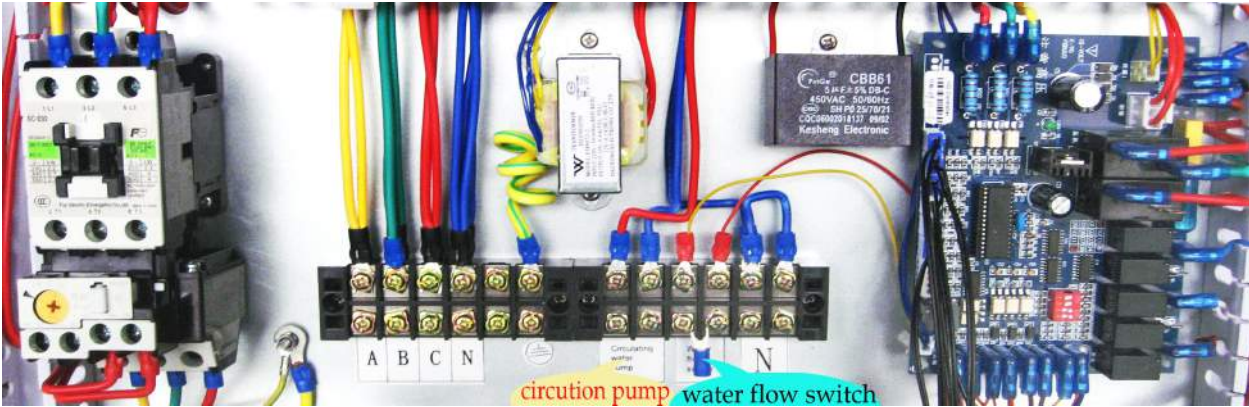

◆ 220V single compressor heat pump wiring diagram

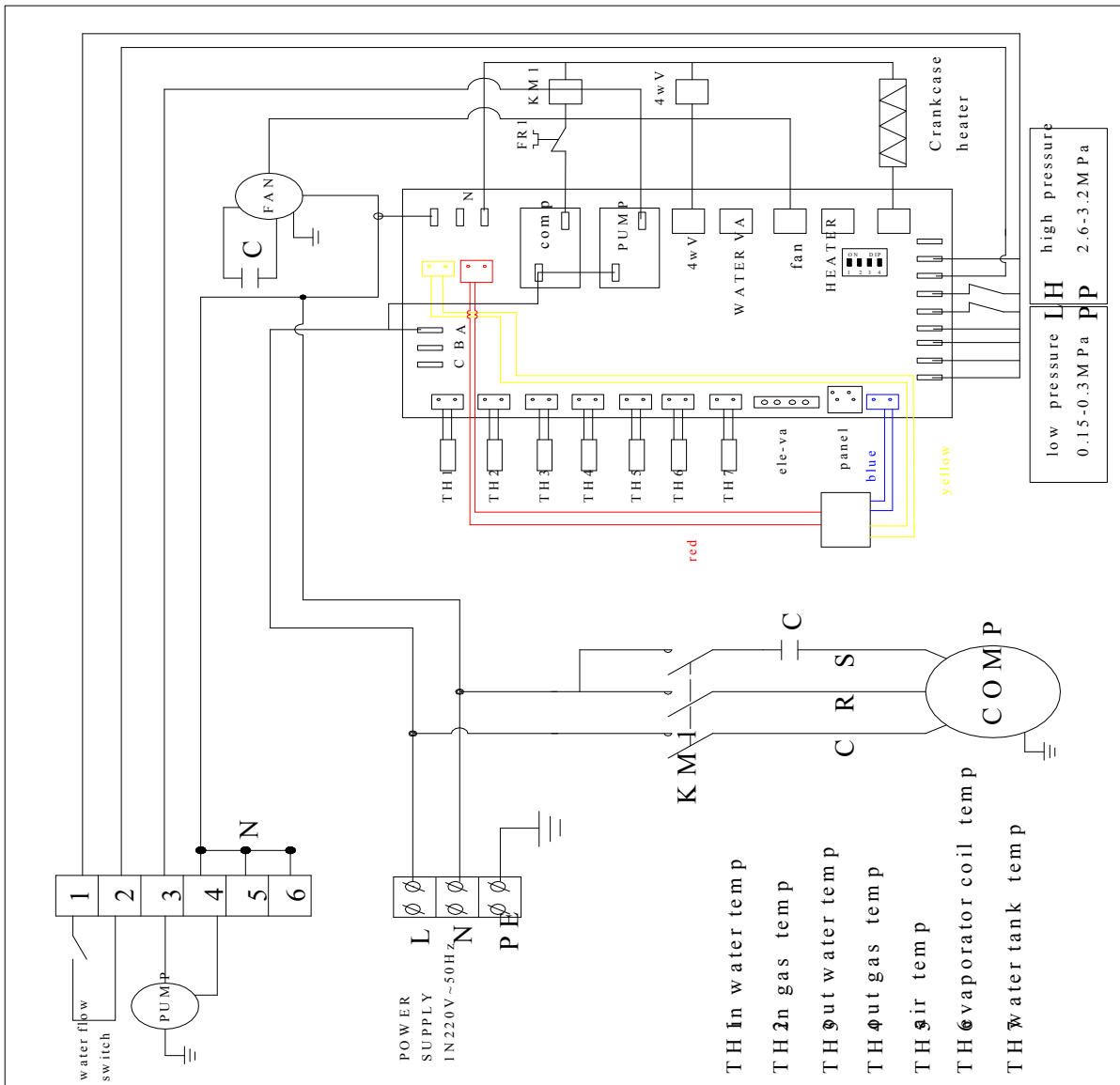

◆ 380V double compressor heat pump wiring diagram

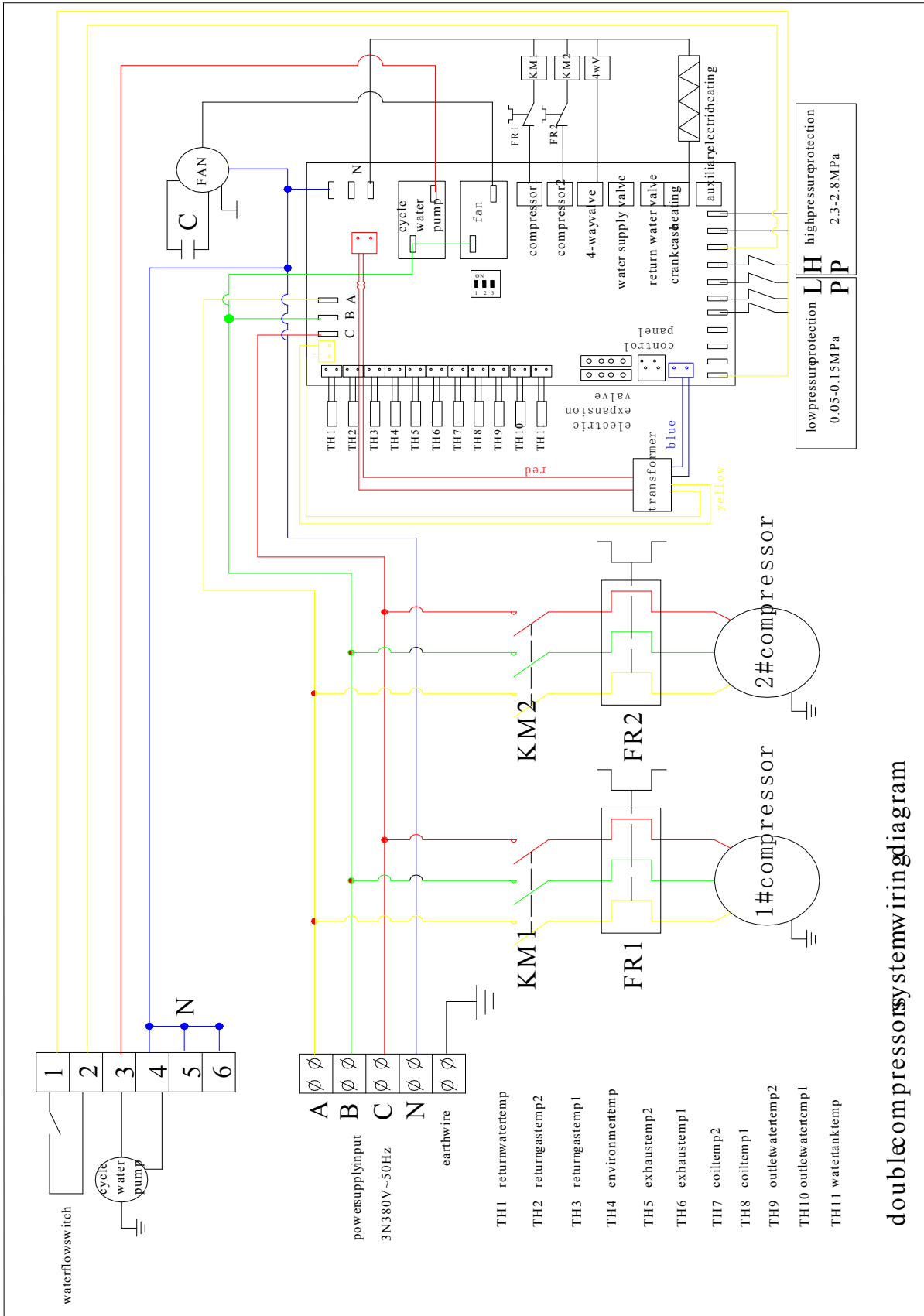

double compressor system wiring diagram



## ※ IX、 Installation instruction

### 1. Installation of the units

#### Selection of installation position

##### Mainframe

- A) It should be installed in place with large place and good ventilation, the installation place should guarantees smooth air exhale(for air inhale , refer to the following figure)
- B) The installation position should be close to drainage channel or vent to facilitate water discharge
- C) Make sure the unit keeps straight up without any inclination after installation.
- D) Do not install the mainframe in place where there is pollution , corrosive gas , or Accumulation of dirt or fallen leaves .
- E) The installation position should not be close to inflammable and explosive places with obvious fire hazards .
- F) Make sure to observe the distance from hindrance shown by arrows in the following figure .
- G) The unit installation foundation can be a concrete structure or steel brackets with anti-vibration rubber pad and smooth surface .
- H) The foundation can nbe designed based on the operation quality of the unit(refer to technical performance parameter list)
- I) The bottom of the foundation should fixed with screw .
- J) There should be drainage channel or vent on the ground
- K) Where the water tank is installed , there should be a concrete foundation

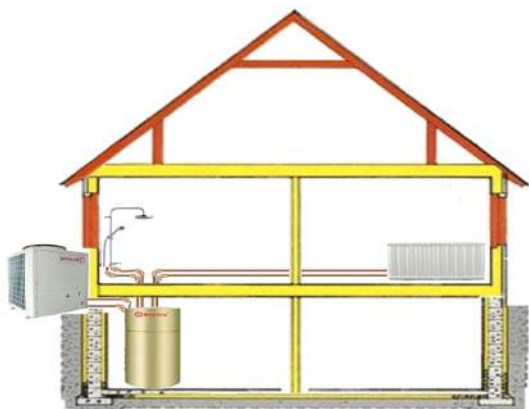

In selecting the heat pump water heater unit to install, check whether the corresponding power supply agrees with the specifications for heat pump water heater unit power. For details, refer to the tag on the unit or the installation and operation instruction.

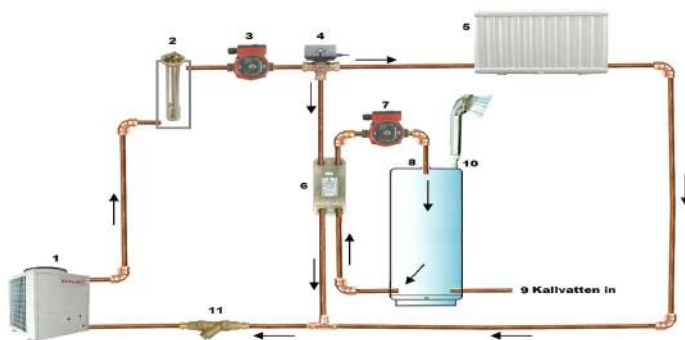

- |                                  |                    |
|----------------------------------|--------------------|
| 1. heat pump                     | 7. water pump      |
| 2. electric heater               | 8. water tank      |
| 3. Water pump                    | 9. out use         |
| 4. Water controller              | 10. shower         |
| 5. Radiant                       | 11. Y shape filter |
| 6. water to water heat exchanger |                    |

## Installation instruction

